



CLA-VAL 403-35e

Remote Control Valve with Manual Override and Pressure Reducing Feature (for Fire Deluge Service)

Simple, Reliable and Accurate

- Single seat with resilient disc insures tight seal
- Simply designed with few working parts
- Quick response to remote control
- Fully supported frictionless diaphragm
- Leak-proof service assured - no packing glands
- Single tube line required for control
- Opens wide for minimum flow resistance

The CLA-VAL 403-35e Remote Control Valve is used where "on-off" control is required. Pneumatic pressure signals from a remote control "opens or closes" a small auxiliary valve installed on the main valve cover, which in turn opens or closes the main valve. Only the small amount of fluid in the auxiliary valve cover must pass through the remote control pilot in order to fully open or close the larger main valve. Pressure reducing control is a normally open control that senses main valve outlet pressure changes. . Isolation ball valve by-pass auxiliary valve.

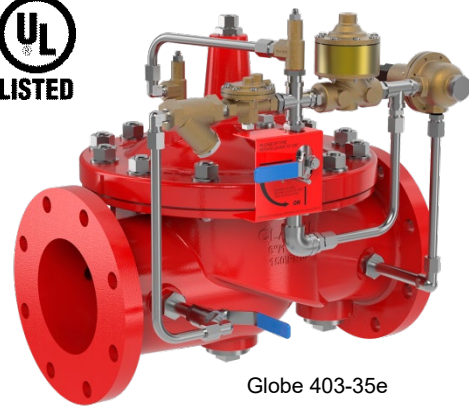

Globe 403-35e

The Model 403-35e consists of a 100G/2100G HYTROL-Deluge main valve and a small HYTROL auxiliary valve. Both the main valve and the auxiliary valve are single-seated, diaphragm operated globe type valves. Line pressure applied to the auxiliary valve cover closes the main valve drip tight.

Function

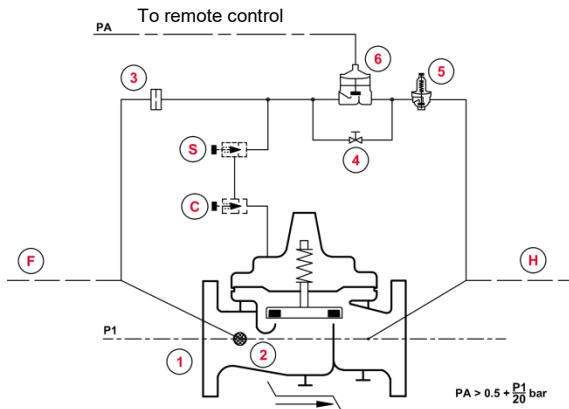

Schematic Diagram

ITEM	DESCRIPTION
1	Model HYTROL-Deluge AE/GE/NGE 100G/2100G
2	X46A Flow clean strainer
3	X58C-CSA Restriction assembly
4	RB-117 Isolation ball valve
5	CRD Pressure reducing control
6	102F/X103 Auxiliary valve

Optional Features

ITEM	DESCRIPTION
C	CV One-way flow control (Closing speed)
F	Remote sensing
H	Drain to atmosphere
S	CV One-way flow control (Opening speed)

Standard Specifications

Sizes:

Globe: 3" - 12" flanged
 Angle: 3" - 12" flanged
 Other sizes upon request

Pressure Ratings:

150 class - 250 psi max.
 300 class - 400 psi max.

Temperature Range:

Water max. 180°F / 82°C

Materials

Main Valve Body & Cover:

Ductile iron ASTM A-536*
 Cast steel ASTM A216 Gr.WCB*
 Naval bronze ASTM B-61
 Ni-Al bronze ASTM B148
 Super duplex SST
 Stainless steel ASTM A743-CF-8M

Main Valve Trim:

Bronze ASTM B61
 Monel
 Stainless Steel 316

*Internally and externally epoxy coated

Standard Pilot System:

Pilot Control:

Cast bronze ASTM B61

Trim:

Monel

Rubber:

Buna-N® synthetic rubber

Tubing & Fittings:

Stainless steel

Optional Pilot System:

Pilot Systems are available with Stainless Steel or Monel materials.

Remote Control Valve with Manual Override and Pressure Reducing Feature (for Fire Deluge Service)

► Dimensions

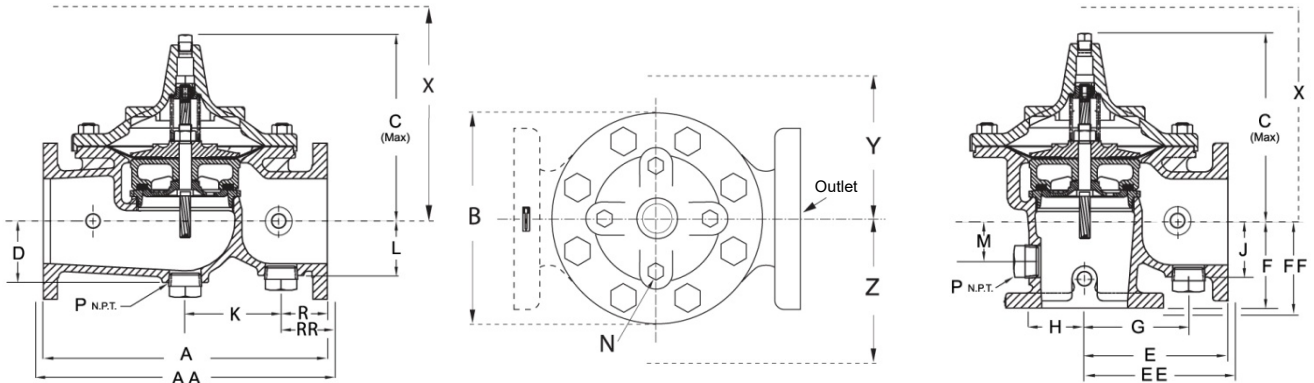

Valve size [inches]	3	4	6	8	10	12
A 150 ANSI	12.00	15.00	20.00	25.38	29.75	34.00
AA 300 ANSI	13.25	15.62	21.00	26.38	31.12	35.50
B Dia.	9.12	11.50	15.75	20.00	23.62	28.00
C Max.	8.19	10.62	13.38	16.00	17.12	21.00
D	2.56	3.19	4.31	5.16	8.50	9.39
E 150 ANSI	7.00	8.50	10.00	12.69	14.88	17.00
EE 300 ANSI	-	8.81	10.50	13.19	-	17.75
F 150 ANSI	4.00	4.97	6.00	8.00	8.62	13.75
FF 300 ANSI	-	5.28	6.50	8.50	-	14.50
G	4.75	5.94	7.25	8.50	10.50	17.00
H	2.69	2.81	3.88	5.31	6.56	7.00
J	2.56	2.81	3.81	4.81	5.81	7.00
K	7.00	4.03	6.75	17.00	15.50	21.00
L	2.56	2.81	3.81	4.81	8.50	9.39
M	1.75	2.41	2.755	4.00	4.24	8.75
N NPT	1/2"	3/4"	3/4"	1"	1"	1"
P NPT	1-1/4"	2"				
R 150 ANSI	2.50	3.47	3.25	4.19	7.12	6.50
RR 300 ANSI	3.12	3.78	3.75	4.69	7.81	7.25
X Pilot System	15.00	17.00	29.00	31.00	33.00	35.00
Y Pilot System	11.00	12.00	20.00	22.00	24.00	26.00
Z Pilot System	11.00	12.00	20.00	22.00	24.00	26.00

Valve size [mm]	80	100	150	200	250	300
A 150 ANSI	305	381	508	645	756	864
AA 300 ANSI	337	397	533	670	791	902
B Dia.	232	292	400	508	600	711
C Max.	208	270	340	406	435	533
D	65	81	110	131	216	239
E 150 ANSI	178	216	254	322	378	432
EE 300 ANSI	-	224	267	350	-	451
F 150 ANSI	102	126	152	203	219	349
FF 300 ANSI	-	134	165	216	-	368
G	121	151	184	216	267	432
H	68	71	99	135	167	178
J	65	71	97	122	148	178
K	178	102	171	432	394	533
L	65	71	97	122	216	239
M	45	61	70	102	108	222
N NPT	1/2"	3/4"	3/4"	1"	1"	1"
P NPT	1-1/4"	2"				
R 150 ANSI	64	88	83	106	181	165
RR 300 ANSI	79	96	95	119	198	184
X Pilot System	381	432	737	787	838	889
Y Pilot System	279	305	508	559	610	660
Z Pilot System	279	305	508	559	610	660

► Valve Capacity

Valve size [mm]	80	100	150	200	250	300
Max. continuous [l/s]	29	50.5	113.6	196	309	442
Max. surge [l/s]	63	114	252	441.6	694	1009

► Functional Data

Valve size		[Inches]	3	4	6	8	10	12
		[mm]	80	100	150	200	250	300
CV Factor	Globe	[gpm]	115	200	440	770	1725	1725
	Pattern	[l/s]	27.6	48	105.6	184.8	414	414
	Angle	[gpm]	139	240	541	990	2500	2500
	Pattern	[l/s]	33.4	58	130	238	600	600

► When Ordering, Please Specify

1. Model No. 403-35e
2. Valve Size
3. Pattern Globe or Angle
4. Pressure class
5. Threaded, flanged or grooved
6. Trim material
7. Adjustment range
8. Desired options
9. When vertically installed